

Venice

VE590FCR

Chrome Swivel Mixer

Lead  **FREE**

All dimensions in mm

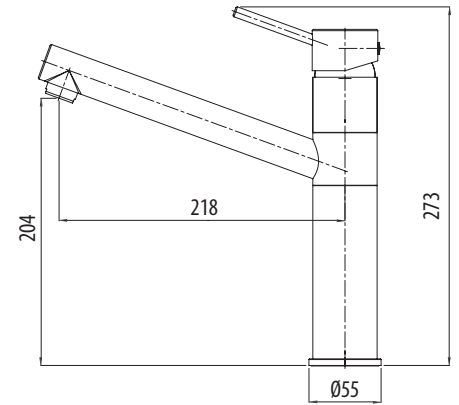

Specifications /

WELS rating	5 Stars, 6.0 L per minute
WELS registration number	T43020
Temperature rating (min / max)	1°C - 80°C
Pressure rating (min / max)	150 kPa - 500 kPa
Finish	Polished chrome
Materials	Lead free brass body
Cartridge size	40 mm
Cartridge type	Ceramic disc cartridge
Carton size	405 x 285 x 60 mm
Product weight	2 kg
Mixer height	273 mm
Water supply	Mains
Warranty	10 years (see Oliveri website for full details)
Maintenance and care instructions	All surfaces should be cleaned with mild liquid detergent or soap and water. Do not use cream cleaners or citrus based cleaning products, as they are abrasive. Use of unsuitable cleaning agents may damage the surface. Any damage caused in this way will not be covered by warranty.