



www.oliverisinks.com



Model No:

833U & 834U

DOWN UNDER MOUNT SINK



Undermount CAD files (DXF & DWG format) can be downloaded from our web site www.oliverisinks.com

INCLUDED ACCESSORIES



AC09 Basket Waste x 1



AC72W 'D' Colander



AC24 Synthetic Preparation Board

Model No. 833U

DIMENSIONS

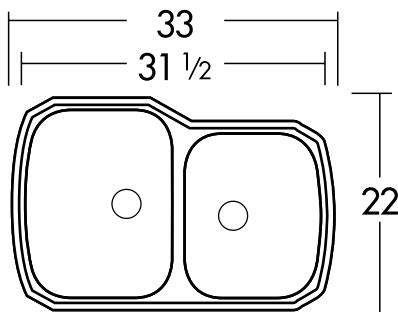

Model No. 834U

DIMENSIONS

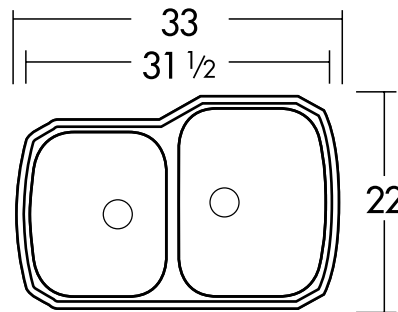

Gourmet Basin
14³/₄ x 19 x 10" deep
10.3 Gallon Capacity



Maxi Basin 1
13³/₄ x 16¹/₂ x 8" deep
6.2 Gallon Capacity



Gourmet Basin
14³/₄ x 19 x 10" deep
10.3 Gallon Capacity



Maxi Basin 1
13³/₄ x 16¹/₂ x 8" deep
6.2 Gallon Capacity

MATERIAL	CONSTRUCTION	SHIPPING WEIGHT	INSTALLATION METHOD	CABINET
Stainless Steel 304 Grade 18 Gauge	Individual bowls welded into rim	(Packed) 28.7 lb	Includes Template and Installation Clips Designed to be under-mounted into a solid surface counter	Minimum 36"



Head Office & Manufacturing Plant
Tasman Sinkware Pty Ltd
51 Naweena Road, Regency Park
South Australia 5010 AUSTRALIA

US Office
PO Box 11120
Wilmington NC 28405
Email contact
tasmansink@aol.com

Manufactured in Australia to highest quality standards. Tasman Sinkware is Quality Endorsed to ISO 9001-2000.